

**Bardstown Sign Ordinance
effective August 22, 2008**

Table of Contents

<u>Section</u>	<u>Page #</u>
Section 1: Purpose	1
Section 2: Applicability	1
Section 3: Conflict with Ordinances, Laws, Rules, & Regulations	1
Section 4: Administration & Interpretation	
4.1 Administration	1
4.2 Interpretation	1
Section 5: Definitions	1 - 6
Section 6: General Sign Requirements	
6.1 General sign regulations	7
6.2 Sign area and height computations	8 – 9
6.3 Construction standards	9
6.4 Maintenance standards	9
6.5 Removal of certain signs	9
Section 7: Signs Exempt from this Ordinance	
7.1 Traffic signs, public notices or warnings	10
7.2 Holiday lights and decorations	10
7.3 Traffic control signs	10
7.4 Civic, philanthropic, educational, or religious organizational event signs in the public right-of-way	10
7.5 Public or semi-public athletic field signs	10
7.6 Temporary window signs	10
Section 8: Signs Not Requiring Permits	
8.1 House or building identification signs	10
8.2 Personal message signs	10
8.3 National, state, local, and corporation flags	10 - 11
8.4 Civic, philanthropic, educational, or religious organizational event signs	11
8.5 Real estate signs	11
8.6 Auction signs	11
8.7 Construction signs	11
8.8 Informational, directional, or historic marker or signs	11
8.9 Community or identification signs	11 - 12
8.10 Election signs	12
8.11 Incidental signs	12
8.12 Subdivision or development signs	12
Section 9: Signs within Historic Overlay Zoning Districts	12
Section 10: Visual Elements Prohibited	12 - 13
Section 11: Signs Requiring Permits	
11.1 Residential or miscellaneous signs	13
11.2 Public or semi-public institutional signs	14
11.3 Commercial, professional office, or industrial signs	14 - 23
Section 12: Permit Process & Procedures	
12.1 Permit required	23
12.2 Application and permit issuance	23 - 24
12.3 Fees	24
12.4 Review	24
12.5 Issuance of permits	24
Section 13: Non-Conforming Signs	24 - 25
Section 14: Violations, Enforcement & Penalties	
14.1 Signs forfeited	25
14.2 Violations	25
14.3 Enforcement	25
14.4 Penalties	26

Bardstown Sign Ordinance effective August 22, 2008

Section 1: Purpose.

The purposes of this Sign Ordinance are:

- 1.1 To encourage the effective use of signs as a means of communication in the City of Bardstown;
- 1.2 To maintain and enhance the aesthetic environment and the City's ability to attract sources of economic development and growth;
- 1.3 To improve pedestrian and traffic safety;
- 1.4 To minimize the possible adverse effect of signs on nearby public and private property; and,
- 1.5 To enable the fair and consistent enforcement of these Sign Regulations.

Section 2: Applicability.

A sign may be erected, placed, established, painted, created, or maintained in the City only in conformance with the standards, procedures, exemptions and other requirements of this Ordinance. The effect of this Ordinance as more specifically set forth herein is:

- 2.1 To establish a permit system to allow a variety of types of signs in commercial and industrial areas and a limited variety of signs in residential areas, subject to the standards and the permit procedures of the Ordinance;
- 2.2 To allow certain signs that are small, unobtrusive and incidental to the principal use of the respective lots on which they are located, subject to the substantive requirements of this Ordinance, without the requirements of a permit;
- 2.3 To provide for small, temporary signs without commercial messages in limited circumstances in the public right-of-way;
- 2.4 To prohibit all signs not expressly permitted by this Ordinance;
- 2.5 To establish a reasonable permit fee; and,
- 2.6 To provide for the enforcement of the provisions of this Ordinance.

Section 3: Conflict with Ordinances, Laws, Rules, & Regulations.

In their interpretation and application, the provisions of this Ordinance shall be held to be minimum requirements adopted for the promotion of the public health, safety, and general welfare. In case of conflict between this Ordinance or any part thereof, and the whole or part of any existing or future local, state, or federal ordinance, law, regulation, or rule, or the whole or part of any existing or future private covenant or deeds, the most restrictive requirement shall apply.

Section 4: Administration & Interpretation.

- 4.1 Administration. The Sign Administrator for the City of Bardstown is charged with the implementation, administration, and enforcement of this Ordinance.
- 4.2 Interpretation. The decision of the Sign Administrator shall be valid in areas of interpretation and vagueness. Appeal of decisions of the Sign Administrator shall be made to the Bardstown City Council.

Section 5: Definitions.

Certain terms are defined for the purposes of this Ordinance. All other words and phrases shall be given their common, ordinary meaning unless the context clearly requires otherwise.

Accessory Building: A building that is structurally independent and detached from, located on the same lot as, and customarily incidental and subordinate to the principal building or use.

Administrator: The Sign Administrator shall be the Joint City-County Planning Commission of Nelson County, unless otherwise designated by the Mayor of the City of Bardstown or his/her designated representative.

Address sign: The numeric reference of a use or building to a street name.

Area of sign: See Sign Area.

**Bardstown Sign Ordinance
effective August 22, 2008**

Attached Sign: See Building Sign.



Illustration 5-1: Attached sign.

Awning: A shelter projecting from and supported by the exterior wall of a building.

Awning sign: A sign painted on, printed on, or attached flat against the surface of an awning.

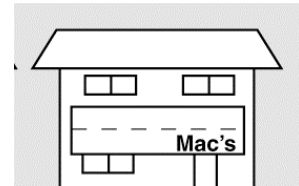
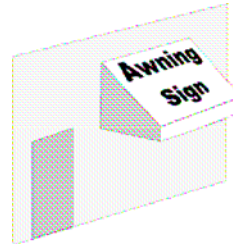

Awning Sign

Illustration 5-2: Awning signs.

Banner: A temporary sign made of cloth, plastic, or other soft material.

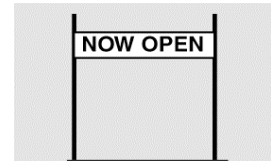

Banner

Illustration 5-3: Banner.

Bench sign: A sign painted on, attached to, or affixed to any portion of a bench or seating area at bus stops or other such pedestrian areas.

Billboard sign: Any off-site sign, available for rent, on a permanent structure on which the copy is periodically changed and which is not located on the premises to which such advertising copy pertains.

Building: As defined in the Zoning Regulations.

Building canopy: A rigid multi-sided structure covered with fabric, metal or other material, supported by a building at one or more points and by columns or posts at the other points, and either internally or externally illuminated.

Building sign: A permanent sign which is connected to, painted on, attached to, or otherwise affixed to a building and includes, but is not limited to, a wall, façade, building canopy, projecting, attached, or awning signs.

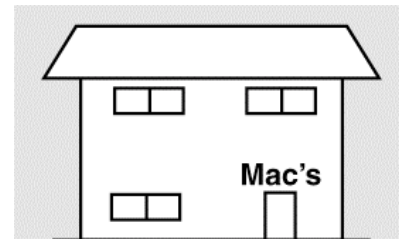

Canopy, Building: See Building Canopy.

Illustration 5-4: Building sign.

Canopy, Freestanding: See Freestanding Canopy.

Canopy sign: A sign painted on, printed on, or attached flat against the surface of a canopy.

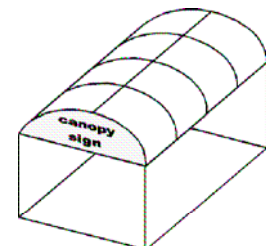

*Illustration 5-5:
Canopy signs.*

Bardstown Sign Ordinance effective August 22, 2008

Changeable copy sign: A sign or portion thereof with characters, letters, or illustrations that can be manually or electronically changed or rearranged without altering the face or the surface of the sign. A sign on which the only copy that changes is an electronic or mechanical indication of time or temperature shall be considered a "time and temperature" portion of a sign and not a changeable copy sign for purposes of this Ordinance. Also known as "reader board," "bulletin board", or "message center."

Construction sign: A sign used to identify the persons, businesses, professions, or trades engaged in an "in-progress" construction project of a building on the site.

Corporation flag: A flag used to advertise a business, institution, organization, or facility located on or at the site and/or the product or service offered on or available at the same lot where the flag is displayed.

Development: A principal building or use or combination of principal buildings and uses, under a common plan with a common or shared identity as indicated by commonality of design and appearance and/or by a commonality of function and use.

Directional sign: On-site permanent sign with no commercial message, logo, or symbol and used only to direct pedestrians or vehicular traffic. Directional signage shall include, but not be limited to, signs for entrances, exits, parking areas, and drive-thrus. See also "Incidental sign."

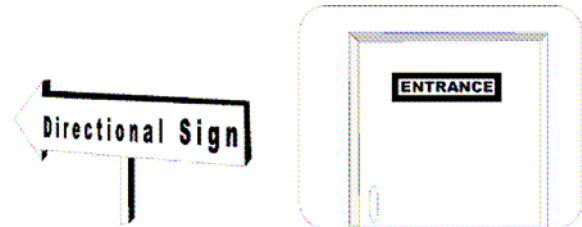

Illustration 5-6: Directional signs.

Directory sign: A building or freestanding sign which lists the names of the occupants of a multiple occupancy building or site.

Election sign: A temporary sign directly associated with national, state or local elections.

Elevation: A geometrical projection of a building on a vertical plane.

Façade sign: See "Building Sign."

Freestanding canopy: A rigid multi-sided structure covered with fabric, metal or other material and supported by columns or posts and either illuminated internally or externally.

Freestanding sign: A permanent sign that is set firmly in or upon the ground surface, is not attached to any building or other structure. Freestanding signs include, but are not limited to, ground-mounted, monument, or pole signs.

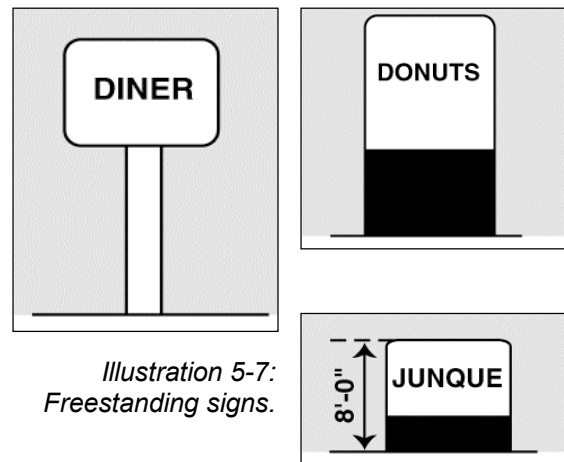

Illustration 5-7:
Freestanding signs.

Grade: The average level of the finished surface of the ground adjacent to a sign or to the exterior wall of the building to which a sign is affixed.

Ground-mounted sign: A freestanding sign with a solid base.

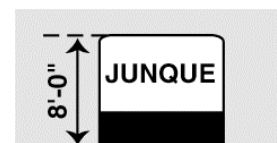

Illustration 5-8:
Ground-mounted sign.

Bardstown Sign Ordinance effective August 22, 2008

Height of sign: See Sign Height.

Historic Overlay Zoning District: A district, landmark, or landmark site that has been designated as having historical, architectural, social, or geographical significance to the community and shall comply with the adopted Design Guidelines and Article 15 of the Zoning Regulations.

Illegal sign: A sign which was not in compliance with this, or the applicable ordinance under which it was erected, installed, altered or displayed.

Illuminated sign: A sign with an artificial light source incorporated internally or externally for the purpose of lighting the sign.

Incidental sign: A sign that has a purpose secondary to the use of the lot on which it is located and is intended merely to provide directions or information. Incidental signs include, but are not limited to, "no parking", "entrance", "loading only", "telephone", and other similar directives. No sign with a commercial message, logo, or symbol and legible from a position off the lot on which the sign is located shall be considered incidental. See also "Directional Sign."

Individual principal use: A principal use located in a structurally independent building and separated with its own building entrance and exit. An accessory use does not constitute an individual principal use.

Landmark sign: A permanent sign or visual element that is designated by the Historic Review Board as having historic and/or architectural significance. A landmark sign shall be at least twenty (20) years old unless the Historic Review Board makes a finding that a newer sign with historic and/or architectural significance should be designated to protect it.

Monument sign: A permanent freestanding sign mounted on the ground and designed with a continuous structural element of approximately the same dimension from the ground to the top of the sign.

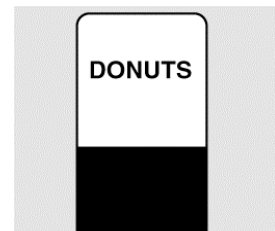

*Illustration 5-9:
Ground-mounted sign*

Non-conforming sign: A sign that was erected, installed, or displayed in compliance with previous sign regulations but which is not in compliance with this Ordinance and which has not been reconstructed, altered, or otherwise modified since the adoption of this Ordinance, except to bring the sign into compliance with the provisions of this Ordinance.

Off-site sign: A permanent sign used to identify, display, advertise, or otherwise direct attention to any business enterprise, commodity, service, or entertainment conducted, sold, or offered at a location other than the premises on which the sign is located. Also referred to as "off-premise sign".

On-site sign: A permanent building sign which identifies or directs attention to a place, activity, business, office, institution, facility, organization, profession, trade, or occupation located at or on the site and/or a product, good, or service offered on or available at the same lot where the sign is displayed. On-site signs shall include, but are not limited to, attached sign, building sign, window sign, freestanding sign, projecting sign, and awning sign. Also referred to as "on-premise sign".

Permitted use: A use which is specifically authorized by right in a particular zoning district, as set forth in the Zoning Regulations.

Permanent sign: A non-temporary sign designed and intended for long-term use.

**Bardstown Sign Ordinance
effective August 22, 2008**

Portable sign: A temporary sign which is not permanently attached or anchored to the ground or other permanent structure, or a sign designed to be transported. Portable signs include, but are not limited to, signs designed to be transported by means of wheels, signs converted to A or T frames, menu and sandwich board signs, balloons or visual elements used as signs; umbrellas used for advertising, and signs attached to or painted on vehicles parked and visible from the public right-of-way.

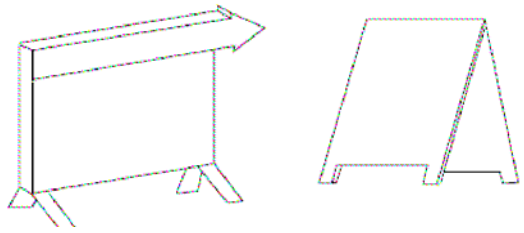
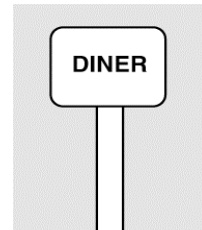

Illustration 5-10: Portable signs.

Pole sign: A permanent freestanding sign mounted on the ground, where the structural element is significantly more narrow than the sign.



*Illustration 5-11:
Pole sign.*

Principal building: A building or combination of buildings of primary importance or function on a site. In general, the primary use of the site is carried out in a principal building.

Principal use: The primary or predominant use of any lot, as distinguished from accessory uses and buildings.

Projecting sign: A permanent building sign which is mounted, erected, or otherwise affixed on a building wall or structure, projecting generally perpendicular to the wall, and extending beyond the building wall more than twelve (12) inches. Projecting signs also include suspended signs.

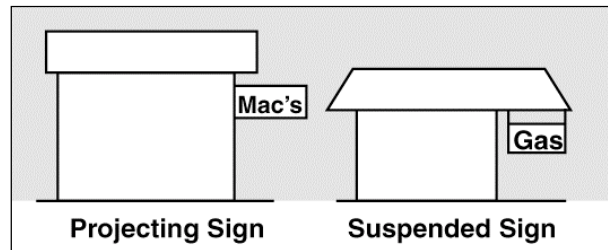

Illustration 5-12: Projecting sign.

Public Institution: Any building used exclusively for public purposes by any department or branch of government, such as schools, libraries, post offices, police, emergency, and fire stations, and utilities and services.

Reader board: See “Changeable copy sign”.

Roof sign: A sign erected and constructed wholly or in part upon, against, or above the roof of a building. For purposes of this Ordinance, any portion of a building above or behind the fascia or parapet of a building shall be considered part of the roof.

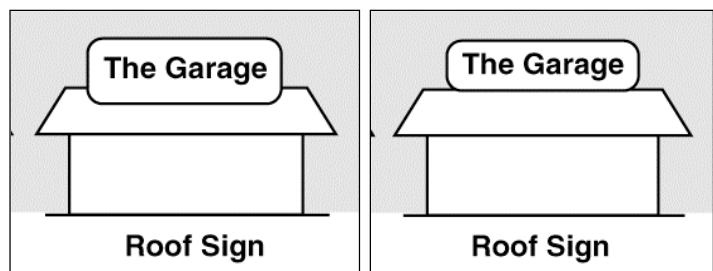

Illustration 5-13: Roof signs.

Roof-integral Sign: Any building sign erected or constructed as an integral or essentially integral part of a normal roof structure of any design, so that no part of the sign extends vertically above the highest portion of the roof and so that no part of the sign is separated from the rest of the roof by a space of more than six (6) inches. For purposes of this Ordinance, any portion of a building above or behind the fascia or parapet of a building shall be considered part of the roof. See also “Building Sign.”

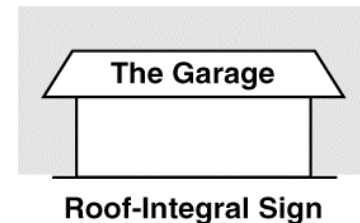

Illustration 5-14: Roof-integral signs.

Bardstown Sign Ordinance effective August 22, 2008

Semi-public Institution: Any building of an institutional nature and serving a public need, such as churches, hospitals, schools, and museums.

Sign: Any device, structure, fixture, display, emblem, picture, placard, visual element, or any parts or combinations thereof using graphics, symbols, and/or written copy for the primary purpose of identifying, providing directions to, drawing attention to, or advertising any activity, place, business, office, institution, facility, organization, profession, trade, occupation, product, good, or service.

Sign area: The total area of the sign face which is used to display a message, not including its supporting poles or structures.

Sign height: The distance from the base of the sign at normal grade to the top of the highest attached component of the sign.

Sign plan: A coordinated plan for developing signs for an individual building or a group of buildings.

Street/road frontage: The distance along which a lot line adjoins a public street or road right-of-way from one lot line intersecting the street to the furthest distant lot line intersecting the same street. For purposes of this Ordinance, a development project containing more than one lot along a street shall be considered to have only one street frontage on that street. Corner lots have at least two (2) street fronts.

Structure: As defined in the Zoning Regulations.

Subdivision Identification Sign: A sign used to identify a residential subdivision on site.

Temporary sign: A sign that is made of paper, cardboard, cloth, plastic, fabric, wood or other materials, which is used for a limited period of time, as set forth in this Ordinance, and which is not permanently mounted. Temporary signs include, but are not limited to, A-frame, banner, wind sign, special event sign, etc.

Time or temperature sign: A sign or portion thereof on which the only copy that changes is an electronic or mechanical indication of time or temperature.

Visual element: A visual element is a substitute for additional signs consisting of temporary and/or permanent device intended to attract attention to any activity, place, business, office, institution, facility, organization, profession, trade, occupation, product, good, or service or to convey message concerning any activity, place, business, office, institution, facility, organization, profession, trade, occupation, product, good, or service.

Wall sign: Any permanent building sign attached parallel to, but within two (2) feet of a wall, painted on the wall surface of, or erected and confined within the limits of any outside wall of any building, which is supported by such wall or building, and which displays only one (1) sign surface. Also see "Building sign."

Window: The combined area of glazing within a wall opening.

Window sign, interior: A sign which is mounted, placed, applied, painted, attached or otherwise affixed inside a window or to the interior of a windowpane or glass and is visible from the exterior of the window. Interior window signs are not considered building signs.

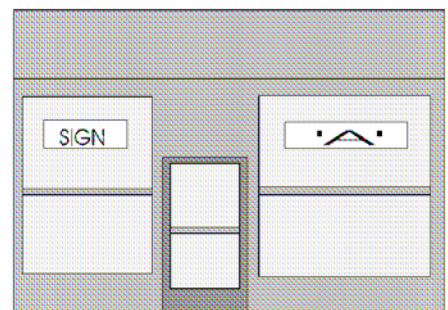

Illustration 5-15: Window signs.

Window sign, exterior: A sign which is mounted, placed, applied, painted, attached or otherwise affixed on the exterior or outside of a window or to a windowpane or glass and is visible from the exterior of the window. Exterior window signs are considered permanent building signs.

Bardstown Sign Ordinance effective August 22, 2008

Section 6: General Sign Requirements.

The information contained within this Section is intended to be used as criteria in all sections of this Ordinance; however, there may be areas that require more detail or explanation. In those cases, the information in those sections shall be used.

6.1 General sign requirements. All signs shall comply with the following general sign requirements:

- 6.1.1 No sign shall be placed in a manner visible from any public street, alley, right-of-way, sidewalk, or other public easement, except as provided herein, nor shall any sign be placed in or extend over street, right-of-way, roadway, sidewalk, public or private utility or access or other easement, or alley, except as provided herein and with the approval of the appropriate agency or utility. Any sign installed or placed on or over public property or right-of-way after adoption of this Ordinance, except in conformance with these requirements, shall be forfeited to the public and subject to confiscation. In addition to other remedies hereunder, the City shall have the right to recover from the owner or person placing such a sign the full cost of removal and disposal of the sign.
- 6.1.2 All signs allowed hereunder shall be constructed and placed so as not to obstruct the vision of the public at any street, alley, or driveway. Signs otherwise permitted by this Ordinance may be located within the sight distance triangle, as shown below, provided that no part of such sign exceeds a horizontal dimension of twelve (12) inches between the height of two and one-half (2 ½) feet and twelve (12) feet above the average grade of each street, alley, or driveway. See illustrations below for visual clearance and sight distance triangle.

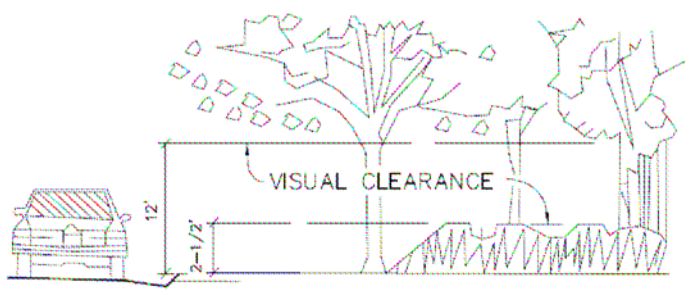

Illustration 6-1.
Visual clearance.

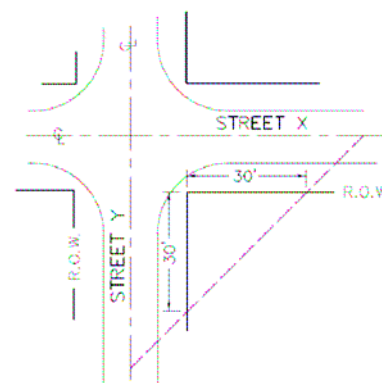

Illustration 6-2.
Sight distance triangle.

- 6.1.3 No sign shall be allowed to be illuminated, except as expressly provided herein. Signs which are otherwise allowed to be illuminated are not allowed if the Sign Administrator finds that the lighting adversely affects adjoining residential uses or causes glare or otherwise interferes with the vision of persons operating motor vehicles. All illuminated signs shall not be flashing or pulsating and shall be constant in intensity and color, unless otherwise allowed herein. Sign lighting shall be directed away from all traffic and from all adjoining residential properties, and the lighting intensity shall not exceed fifteen (15) foot candles at any point on the sign face.
- 6.1.4 No sign shall be allowed to revolve, rotate, or move, unless otherwise expressly provided herein.
- 6.1.5 No sign shall be allowed if the Sign Administrator finds that the sign is constructed or designed in a manner which may cause the sign to be confused with a traffic sign or other traffic control device.

Bardstown Sign Ordinance
effective August 22, 2008

6.2 Sign area and height computations. The following principles shall control the computations of sign area and sign height:

6.2.1 Computation of area of individual signs. The area of a sign face (which is also the sign area of a wall sign or other sign with only one face), shall be computed by means of the smallest square, circle, rectangle, triangle, or combination thereof that will encompass the extreme limits of the writing, representation, emblem, or other display, together with any material or color forming an integral part of the background of the display or used to differentiate the sign from the backdrop or structure against which it is placed, but not including any supporting framework, bracing or decorative fence or wall when such fence or wall is clearly incidental to the display itself.

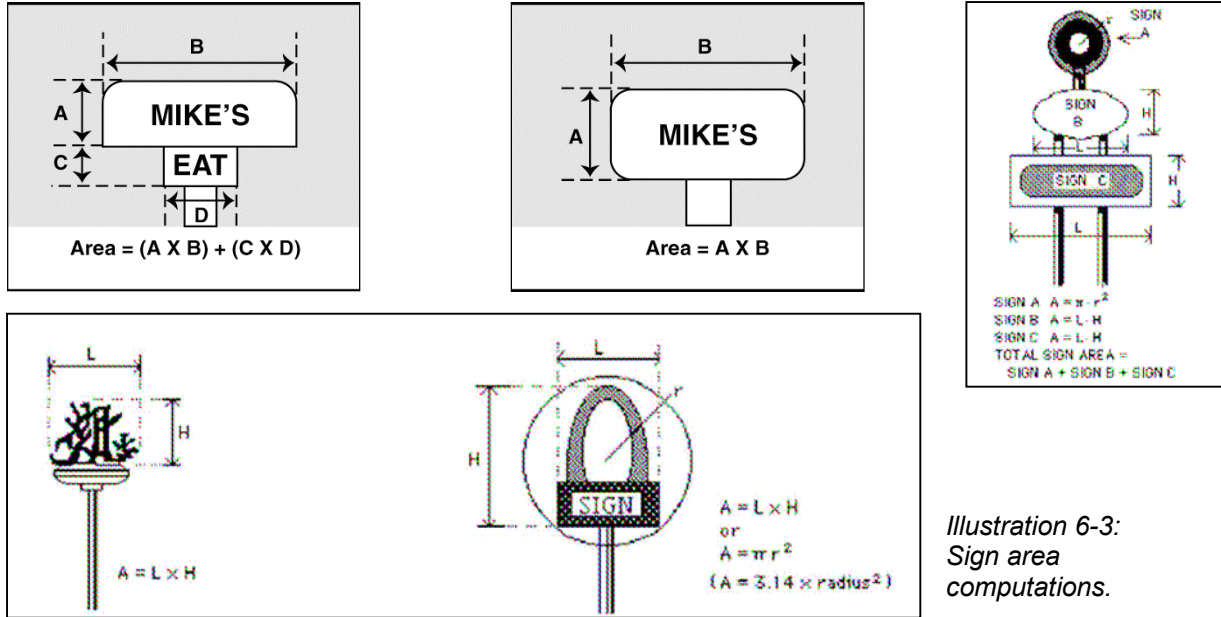

*Illustration 6-3:
Sign area
computations.*

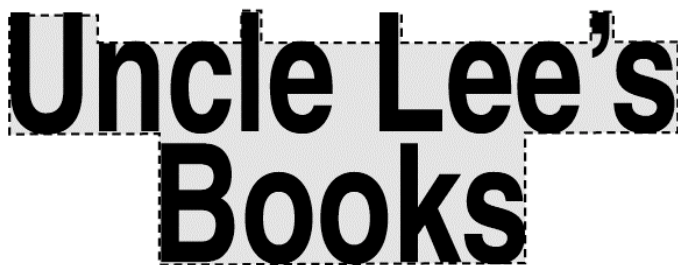

*Illustration 6-4.
Sign area computation for
permanent building sign with no
defined sign background
(e.g., channel letters).*

6.2.2 Computation of area of multi-faced signs. The sign area for a sign with more than one face shall be computed by adding together the area of all sign faces visible from any one point. When two identical sign faces are placed back-to-back so that both faces cannot be viewed from any point at the same time, and when such sign faces are part of the same sign structure and are not more than forty-two (42) inches apart, the sign area shall be computed by the measurement of one of the faces.

6.2.3 Computation of height. The height of a sign shall be computed as the distance from the base of the sign at normal grade to the top of the highest attached component of the sign. Normal grade shall be construed to be the lower of (1) existing grade prior to construction, or (2) the newly established grade after construction, exclusive of any filling, berming, mounding, or excavating solely for the purpose of locating the sign. In cases in which the normal grade cannot reasonably be determined, sign height shall be computed on the assumption that the

**Bardstown Sign Ordinance
effective August 22, 2008**

elevation of the normal grade at the base of the sign is equal to the elevation of the normal grade at the base of the sign is equal to elevation of the nearest point of the crown of a public street or the grade of the land at the principal entrance to the principal building on the lot, whichever is lower. When a sign is within the building setback, the calculation for the sign may use either the base elevation or the elevation of the roadway. The computation of sign height shall include the permitted sign and any attached changeable copy sign or reader board and the sign structure.

Illustration 6-6: Sign height computation.

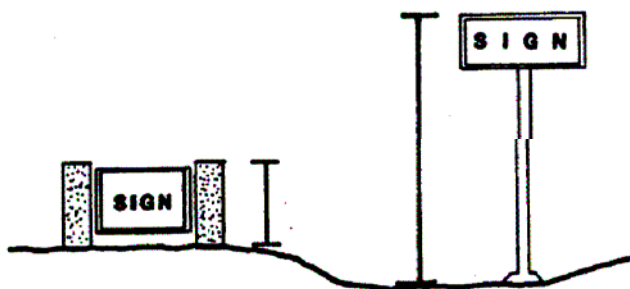
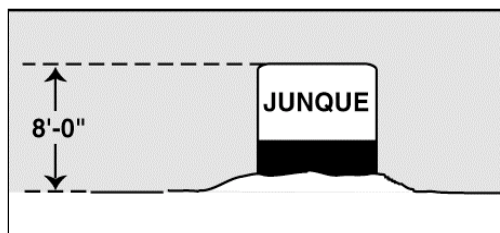

*Illustration 6-7:
Sign height computation in cases where
the normal grade cannot reasonably be
determined*

6.3 Construction standards. All signs shall be constructed and maintained in compliance with the applicable provisions of Kentucky Building Code and other provisions of the Bardstown Code of Ordinances. All illuminated signs shall be installed in accordance with the applicable provisions of the National Electric Code, and all detached signs shall be so illuminated by an underground electrical source.

6.4 Maintenance standards. All signs shall be maintained in good structural and aesthetic condition. Deficiencies, such as chipped paint, broken plastic, missing letters, and exposed light bulbs, shall be evidence of lack of maintenance.

6.5 Removal of certain signs. In the event an establishment ceases operation for a period of thirty (30) days, the sign owner, lessee, or property owner shall immediately remove any non-conforming signs identifying or advertising the business or any product. This requirement shall not apply where, under the provisions of this Ordinance, an existing, conforming sign may be altered to advertise a new principal use, business, establishment, or product, and there is evidence that a new establishment will be in operation on the premises within thirty (30) days. Where no such evidence exists, the sign face shall be removed or the message shall be painted over in such a manner as to completely cover up or hide from sight the message. Upon failure of the sign owner, lessee, or property owner to comply with this Section, the Administrator shall issue a written notice to the owner. The notice shall state that the sign shall be removed within ten (10) days. If the owner fails to comply with the written notice to remove the sign, the Administrator is hereby authorized to cause removal of the sign. Any expense incidental to the removal of the sign shall be charged to the owner and shall constitute a lien upon the property. For the purpose of dealing with non-conforming signs in this Section, the word "remove" shall mean:

- 6.5.1 The sign face, along with posts, columns, or supports of freestanding signs, shall be taken down and removed from the property;
- 6.5.2 The sign face and supporting structures of "projection", "roof" or "wall" signs shall be taken down and removed from the property;
- 6.5.3 The sign face of "painted wall signs" shall be removed by painting over the wall sign in such a manner as to completely cover up and hide from sight the sign in question.

Bardstown Sign Ordinance effective August 22, 2008

Section 7: Signs Exempt from This Ordinance.

Provided that the following signs or visual elements contain no commercial message, logo, or symbol and comply with the general sign regulations set forth in Section 6 of this Ordinance, these signs shall be exempt from all other provisions of this Ordinance:

- 7.1 Traffic signs public notices or warnings required by a valid and applicable federal, state, or local law, regulation, or ordinance;
- 7.2 Holiday lights and decorations on residential lots with no commercial message, logo, or symbol;
- 7.3 Traffic control signs on private property, such as stop, yield, and similar signs, and which contain no commercial message, logo, or symbol;
- 7.4 Civic, philanthropic, educational, or religious organizational event signs within a public right-of-way, provided:
 - 7.4.1 Temporary signs shall announce or relate to a campaign, drive or event of a civic, philanthropic, educational, or religious organization;
 - 7.4.2 For signs within state rights-of-way, an encroachment permit shall be obtained from the Kentucky Transportation Cabinet;
 - 7.4.3 For signs within the county rights-of-way, written permission shall be obtained from Nelson County Fiscal Court;
 - 7.4.4 For signs within the city rights-of-way, written permission shall be obtained from the City of Bardstown; and,
 - 7.4.5 Such signs shall be removed promptly upon the conclusion of the event.
- 7.5 Public or semi-public athletic field signs which indicate sponsorship of the teams or announce or relate to activities that occur therein, provided:
 - 7.5.1 Such signs shall be affixed, placed, or installed on the athletic field fencing and facing the field, and,
 - 7.5.2 Such signs shall not be affixed to scoreboards, buildings, or structures.
- 7.6 Interior window signs.

Section 8: Signs Not Requiring Permits.

The followings signs are allowed on private property without permits, provided that the signs contain no commercial message, logo, or symbol and comply with the general sign regulations set forth in this Ordinance:

- 8.1 House or building identification signs, such as address and building marker, provided:
 - 8.1.1 One (1) sign, not exceeding four (4) square feet in area, shall be permitted, and,
 - 8.1.2 Such signs shall be attached to the referenced building.
- 8.2 Personal message signs, such as birthday, anniversary, and birth announcements or other non-commercial messages, provided:
 - 8.2.2 One (1) sign, not exceeding six (6) square feet in area, shall be permitted; and,
 - 8.2.3 Such signs shall be displayed no longer than fourteen (14) days.
- 8.3 National, state, local and corporation flags provided:
 - 8.3.1 The United States of America flag, Commonwealth of Kentucky flag, or flags of any other national or political subdivision shall be flown and displayed in a manner so that the flags are not construed as an attraction gaining device for the advertising of a product or use, or in a manner to otherwise draw the attention of the traveling public to an establishment;
 - 8.3.5 One (1) corporation flag shall be flown in conjunction with the United States or Commonwealth of Kentucky flag and as part of the display;
 - 8.3.2 Such displays shall not exceed twenty-five (25) square feet in area in any residential area or sixty (60) square feet in any commercial or industrial area;

**Bardstown Sign Ordinance
effective August 22, 2008**

- 8.3.3 Such displays shall not be flown from a pole the tip of which is more than twenty-five (25) feet in height;
 - 8.3.4 Such displays shall conform to the criteria established in the Ninety-Fourth Session of Congress (94-344; SJ Resolution 49); and,
 - 8.3.6 Only one (1) flag display shall be permitted for each establishment, and the display shall be located at the principal building of the facility.
- 8.4 Civic, philanthropic, educational, or religious organizational event signs announcing or related to a campaign, drive, or event of a civic, philanthropic, educational, or religious organization, provided:
- 8.4.1 One (1) temporary sign, not exceeding forty (40) square feet and seven (7) feet in height, and small balloons, not exceeding 12-inch in diameter, shall be permitted on the site of the campaign, drive, or event;
 - 8.4.2 Such signs shall be removed within forty-eight (48) hours of the conclusion of the event to which the sign relates;
 - 8.4.3 Such signs must be securely installed or displayed and shall be constructed or designed in a manner which shall not cause the sign to be confused or interfere with a traffic sign or other traffic control device; and,
 - 8.4.4 Such signs may be ground-mounted or building-mounted, and if building-mounted, the signage shall not extend above the peak, or highest point of the roof.
- 8.5 Real estate signs indicating the sale or rental of the premises, provided:
- 8.5.1 One (1) sign shall be permitted on the premises being sold or rented;
 - 8.5.2 For lots or tracts of five (5) acres in size or less, such signs shall not exceed eight (8) square feet, with maximum two (2) sign faces, and seven (7) feet in height;
 - 8.5.3 For lots or tracts greater than five (5) acres in size, such signs shall not exceed thirty-two (32) square feet, with maximum two (2) sign faces, and seven (7) feet in height; and,
 - 8.5.4 Such signs shall be removed no later than one (1) week after the closing of the sale or lease.
- 8.6 Auction signs advertising and announcing the auction of real and personal property, provided:
- 8.6.1 One (1) sign shall be permitted on the premises of the auction;
 - 8.6.2 Such sign shall not exceed thirty-two (32) square feet in size, with maximum two (2) sign faces, and seven (7) feet in height; and,
 - 8.6.3 Such signs shall be displayed only for the fourteen (14) calendar days immediately preceding the auction's date and shall be removed on the day that the auction is held.
- 8.7 Construction signs identifying the persons, businesses, professions, or trades engaged in an "in-progress" construction project of a building on the site, provided:
- 8.7.1 One (1) sign per contractor and one (1) sign per financial institution offering service(s) on the property shall be permitted;
 - 8.7.2 For lots less than two (2) acres in size, such signs shall not exceed eight (8) square feet, with maximum two (2) sign faces and seven (7) feet in height;
 - 8.7.3 For lots greater than two (2) acres in size, such signs shall not exceed thirty (32) square feet, with maximum two (2) sign faces, and seven (7) feet in height; and,
 - 8.7.4 Such signs shall be removed no later than one (1) week after final occupancy of the site or completion of the service, whichever is longer.
- 8.8 Informational, directional or historic marker or signs erected by a public agency that contain no message referring to any specific business or commercial activity and are non-commercial in nature.
- 8.9 Community identification signs containing the town or community name and/or civic organizational names, such as Kiwanis, Rotary, Jaycees, etc., but not including semi-public institutions, provided:
- 8.9.1 Such signs shall contain no message referring to any specific business or commercial activity and shall be non-commercial in nature;
 - 8.9.2 Such signs shall only be displayed on a group sign structure;
 - 8.9.3 Such group sign structures shall only be located in a commercial or industrial district within ¼ mile of the Bardstown corporate limits;

**Bardstown Sign Ordinance
effective August 22, 2008**

- 8.9.4 Such group sign structures shall not exceed seven (7) feet in height and fifty (50) square feet in sign area; and,
- 8.9.5 Such group sign structures require approval of the Bardstown City Council.
- 8.10 Election signs announcing or supporting political candidates or issues in connection with any national, state, or local election, provided:
 - 8.10.1 Such signs shall be removed within ten (10) days following the election to which it applies, and the owner of the property on which the sign is placed shall be responsible for its removal;
 - 8.10.2 Such signs may be placed on private fences with the property owner's permission and shall be removed within ten (10) days after the election;
 - 8.10.3 Such signs may not be erected or placed on public property or on rocks, trees, public fences, sign posts, light poles, or utility poles on public property; and,
 - 8.10.4 Property owners shall be responsible for violations.
- 8.11 Incidental signs that are informational and have a purpose secondary to the use of the lot on which it is located, such as "no parking," "entrance," "loading only," "telephone," and other similar directives, provided that the signs contain no commercial message or logo.
- 8.12 Subdivision or development signs that indicate that property or lots within the subdivision are "for sale" or are under development or that a multi-family residential development is under construction and will soon be offered for rent or sale, provided:
 - 8.12.1 One (1) temporary sign per subdivision entrance shall be permitted;
 - 8.12.2 Such signs may be non-illuminated or indirectly-illuminated;
 - 8.12.3 Such signs shall not exceed thirty-two (32) square feet in area and seven (7) feet in height; and,
 - 8.12.4 Upon sale of ninety (90) percent of the lots or property within a subdivision or development or ninety (90) percent rental of the units in a multi-family residential development, such signs shall be removed.

Section 9: Signs within Historic Overlay Zoning Districts.

The number, size, height, appearance and location of signage within an historic overlay zoning district shall comply with adopted Design Guidelines and Article 15 of the Zoning Regulations. Any sign not previously approved by the Bardstown Historical Review Board and Bardstown City Council will be considered non-conforming as of the enactment of this Ordinance until found to be appropriate by subsequent action of the Bardstown Historical Review Board and Bardstown City Council. All non-conforming signs will be subject to Section 13 of this Ordinance. Sections 1 through 6 and 12 through 14 of this Ordinance shall also apply to signage within an historic overlay zoning district.

Section 10: Visual Elements Prohibited.

Visual elements, as defined in Section 5 of this Ordinance, are prohibited in all circumstances whether added to a sign or simply displayed on a property, unless otherwise allowed in this Ordinance. Visual elements include, but are not limited to:

- 10.1 Pennants or streamers, with or without commercial message, logo, or symbol;
- 10.2 Large or small balloons, with or without commercial message, logo, or symbol;
- 10.3 Flashing lights, flashing arrows, or other pulsating fixtures or items;
- 10.4 Large inflatable displays, fixed or portable, that indicate through direct representation or through symbolism, a use or service undertaken and/or a product or good offered on the property on the site;
- 10.5 Large displays of permanent construction, fixed or portable, that indicate through direct representation or through symbolism, a use or service undertaken and/or a product or good offered on the property on the site and that are larger than the maximum cube dimensions of seven (7) feet in height, four (4) feet in depth, and four (4) feet in width, as set forth in Section 11.3.2.2.6 of this Ordinance; and,

**Bardstown Sign Ordinance
effective August 22, 2008**

10.6 Wording, murals, paintings, message, or any commercial logo, symbol, or depiction on the exterior of a building, or any structural element thereof, any independent structure or any other article or item on the property, including automobiles or other vehicles, unless permanently painted or adhered on the vehicle and the vehicle retains its mobility and is moved twice per week.

Section 11: Signs Requiring Permits

The following signs shall not be erected, placed, established, painted, installed, or created until an approved sign permit has been issued by the Sign Administrator and shall comply with the general sign regulations set forth in this Ordinance and as set forth below:

11.1 Residential or Miscellaneous Signs.

11.1.1 Subdivision identification signs identifying the subdivision or development name, provided:

- 11.1.1.1 One (1) sign per each side of a subdivision entrance shall be permitted;
- 11.1.1.2 Such signs shall be indirectly-illuminated;
- 11.1.1.3 Such signs shall not exceed twenty (20) square feet in area; and,
- 11.1.1.4 The entire sign structure shall not exceed twenty-five (25) feet in length and eight (8) feet in height.

11.1.2 Building identification signs identifying the name of the owner or occupant of the building, provided:

- 11.1.2.1 One (1) sign shall be permitted and shall not exceed one (1) square foot in area;
- 11.1.2.2 Such signs shall be attached to the building, and,
- 11.1.2.3 Such signs shall not be illuminated.

11.1.3 Multi-family residential development identification signs identifying only the name of the multi-family residential building or development, provided:

- 11.1.3.1 One (1) sign shall be permitted and may be wall- or ground-mounted;
- 11.1.3.2 Such signs shall not exceed twenty (20) square feet in area;
- 11.1.3.3 If ground-mounted, the sign shall be set back at least ten (10) feet from the right-of-way line or property line; and,
- 11.1.3.4 Such signs shall not exceed eight (8) feet in height.

11.1.4 Multi-family residential development directional signs, provided:

- 11.1.4.1 A multi-family residential development shall be permitted one (1) directional sign per each public road/street frontage;
- 11.1.4.2 Such signs shall be illuminated by indirect or diffused lighting
- 11.1.4.3 Such signs shall not exceed three (3) square feet in area; and,
- 11.1.4.4 Such signs shall be wall-mounted, or if ground-mounted, shall be set back at least five (5) feet from the right-of-way line or property line.

11.1.5 Home occupation signs, provided:

- 11.1.5.1 One (1) sign shall be permitted, and,
- 11.1.5.2 Such signs shall not exceed six (6) square feet in area and must be wall-mounted.

11.1.6 Conditional use signs provided:

- 11.1.6.1 One (1) sign shall be permitted;
- 11.1.6.2 Such signs shall not exceed ten (10) square feet in area; and,
- 11.1.6.3 Such signs shall be wall-mounted or freestanding.

**Bardstown Sign Ordinance
effective August 22, 2008**

- 11.2 Public or Semi-Public Institutional Signs, indicating the name of the institution, provided:
- 11.2.1 One (1) sign, not exceeding twenty-five (25) square feet in area and seven (7) feet in height, shall be permitted;
 - 11.2.2 Such signs may be indirectly or interiorly illuminated; and,
 - 11.2.3 Such signs may also have one (1) reader board, provided that such reader board shall be attached to the principal sign and shall not exceed fifteen (15) square feet in area.
- 11.3 Commercial, Professional Office, and Industrial Signs.
- 11.3.1 Temporary Signs providing directions to, drawing attention to, or advertising special sale, event, activity, use, good, service, or product provided, sold, or conducted on the site, provided:
- 11.3.1.1 One (1) sign, not exceeding forty (40) square feet and seven (7) feet in height, and small balloons, not exceeding 12-inch in diameter, shall be permitted;
 - 11.3.1.3 Such signs must be securely installed or displayed and shall be constructed or designed in a manner which shall not cause the sign to be confused or interfere with a traffic sign or other traffic control device; and,
 - 11.3.1.4 Such signs may be ground-mounted or building-mounted, and if building-mounted, the signage shall not extend above the peak, or highest point of the roof;
 - 11.3.1.5 Where a single-building or complex of buildings contains two (2) or more principal uses with their own separate exterior customer entrances, each principal use located therein shall be permitted temporary signage as set forth above; and,
 - 11.3.1.6 Each principal use shall be allowed up to four (4) temporary sign permits per calendar year, and each permit is for one (1) seven (7) day period.
- 11.3.2 Permanent signs used for drawing or attracting attention to, providing as a symbol of, or conveying message concerning any activity, use, good, service, or product provided, sold, or conducted on the site, provided:
- 11.3.2.1 Maximum Number of Permanent Signs:
- 11.3.2.1.1 Individual principal use. An individual principal use located on an individual lot shall be allowed a maximum total of four (4) signs, unless otherwise allowed in this Ordinance.
 - 11.3.2.1.2 Multi-tenant and multi-use building with two (2) or more principal uses without their own separate exterior building entrances and exits and sharing a common hallway.
 - (a) The building shall be allowed a maximum total of four (4) permanent signs, unless otherwise allowed in this Ordinance.
 - 11.3.2.1.3 Multi-tenant and multi-use buildings and developments where a single building or complex of buildings contains two (2) or more individual principal uses with their own separate exterior building entrances and exits.
 - (a) Building Signs. Unless otherwise allowed in this Ordinance, the number and size of permanent building signs for each principal use located within the development shall be based on the portion of the building elevation occupied by the use.
 - (b) Freestanding Signs. The number and size of freestanding signs for a multi-tenant and multi-use building and development shall be based on the total building size and public street frontage of the entire development. Individual buildings and uses within the development shall not be permitted individual freestanding signs.

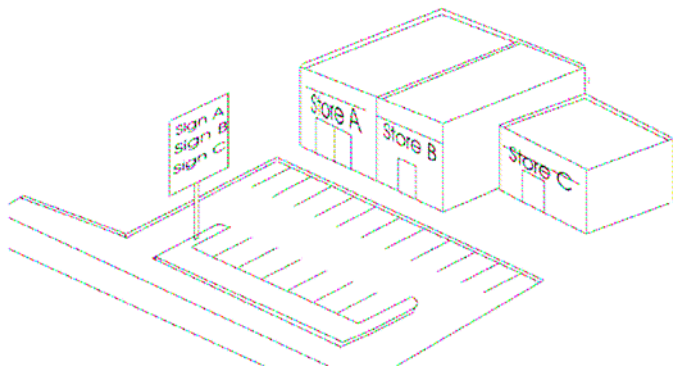

*Illustration 11-1.
Multi-use building sign types.*

11.3.2.2 Permanent Sign Types.

11.3.2.2.1 Freestanding Signs.

(a) Developments with gross floor space **less** than ten thousand (10,000) square feet and **less** than two hundred (200) feet of public road/street frontage:

- (1) Maximum number of freestanding signs. One (1) freestanding sign.
- (2) Maximum sign area and height:
 - (aa) For freestanding signs with a maximum height of seven (7) feet, the maximum sign area shall not exceed fifty (50) square feet.
 - (bb) For freestanding signs with a maximum height of twenty (20) feet, the maximum sign area shall not exceed thirty (30) square feet.
 - (cc) When a freestanding sign is located more than sixty-five (65) feet from the driving lane of a public road/street with forty-five (45) mile per hour (MPH) or greater speed limit, the maximum sign area shall not exceed seventy (70) square feet, and the maximum sign height shall not exceed ten (10) feet.
- (3) Minimum setbacks: The minimum setback for freestanding signs shall be ten (10) feet from rear and side property lines and off of the right-of-way of any public road/street, unless otherwise stated in this Ordinance.
- (4) Changeable copy sign: Each freestanding sign may have attached to it a changeable copy sign, provided:
 - (aa) Such sign shall not exceed one-half (1/2) the sign area of the permitted freestanding sign on which it is attached;
 - (bb) Such sign may be electronic, such as light emitting diode (LED), provided:
 - (i) Such sign shall be limited to text only, and the text shall be static and in a stationary and fixed position;
 - (ii) Such sign shall have a black opaque background and shall be limited to monochrome text in amber, green, blue, red, or white color;
 - (iii) Such sign shall not flash, scroll, chase, rotate, blink or pulsate or have any similar effects of movement;
 - (iv) Such sign shall not include any animated images and images which move or give the appearance of movement and shall not have visual messages with apparent motion caused by, but not limited to, the illusion of moving objects, moving patterns or

boards of lights, expanding, contracting, or rotating shapes, scrolling or running messages, or other similar animation effects;

- (v) Such sign shall be programmed so that the text changes no more than every minute, and such changes of text shall be substantially instantaneous as seen by the human eye and shall not use fading, rolling, window shading, dissolving, or similar effects as part of the change;
- (vi) Such signs shall use automated light sensing devices to reduce light levels at night and under cloudy or other darkened conditions, in accordance with the following standards:
 - (vi-1) Such electronic signs shall have installed automated light sensing devices (e.g., photocell technology) and shall, at all times, allow such monitors to automatically adjust the brightness level based on ambient light conditions, and,
 - (vi-2) Maximum brightness levels for such electronic signs shall not exceed 500 nits, when measured from the sign face at its maximum brightness, during night and under cloudy or other darkened conditions;
- (vii) The maximum resolution of such signs shall be 46 millimeter (1.8 inch) pixel pitch.
- (viii) Any electronic sign which malfunctions, fails, or ceases to operate in its usual or normal programmed manner causing therein motion, movement, flashing, or any other similar effects, shall be repaired or disconnected within 48 hours by the owner or operator of such sign; and,
- (ix) Permit applications for such electronic signs shall be accompanied by additional documentation as set forth in Section 12.2.3.2(e) of this Ordinance.

(b) Developments with gross floor space **less** than ten thousand (10,000) square feet and **more** than two hundred (200) feet of public road/street frontage:

- (1) Maximum number of freestanding signs. Two (2) freestanding signs.
- (2) Maximum sign area and height:
 - (aa) For freestanding signs with a maximum height of seven (7) feet, the maximum sign area shall not exceed fifty (50) square feet.
 - (bb) For freestanding signs with a maximum height of twenty (20) feet, the maximum sign area shall not exceed thirty (30) square feet.
 - (cc) When a freestanding sign is located more than sixty-five (65) feet from the driving lane of a public road/street with forty-five (45) mile per hour (MPH) or greater speed limit, the maximum sign area shall not exceed seventy (70) square feet, and the maximum sign height shall not exceed ten (10) feet.
- (3) Minimum setbacks: The minimum setback for freestanding signs shall be ten (10) feet from rear and side property lines and off of the right-of-way of any public road/street, unless otherwise stated in this Ordinance.
- (4) Minimum sign separation: The minimum separation between two (2) freestanding signs on a lot or tract shall be one hundred fifty (150) feet.

- (5) Changeable copy sign: Each freestanding sign may have attached to it a changeable copy sign, provided:
- (aa) Such sign shall not exceed one-half (1/2) the sign area of the permitted freestanding sign on which it is attached;
 - (bb) Such sign may be electronic, such as light emitting diode (LED), provided:
 - (i) Such sign shall be limited to text only, and the text shall be static and in a stationary and fixed position;
 - (ii) Such sign shall have a black opaque background and shall be limited to monochrome text in amber, green, blue, red, or white color;
 - (iii) Such sign shall not flash, scroll, chase, rotate, blink or pulsate or have any similar effects of movement;
 - (iv) Such sign shall not include any animated images and images which move or give the appearance of movement and shall not have visual messages with apparent motion caused by, but not limited to, the illusion of moving objects, moving patterns or boards of lights, expanding, contracting, or rotating shapes, scrolling or running messages, or other similar animation effects;
 - (v) Such sign shall be programmed so that the text changes no more than every minute, and such changes of text shall be substantially instantaneous as seen by the human eye and shall not use fading, rolling, window shading, dissolving, or similar effects as part of the change;
 - (vi) Such signs shall use automated light sensing devices to reduce light levels at night and under cloudy or other darkened conditions, in accordance with the following standards:
 - (vi-1) Such electronic signs shall have installed automated light sensing devices (e.g., photocell technology) and shall, at all times, allow such monitors to automatically adjust the brightness level based on ambient light conditions, and,
 - (vi-2) Maximum brightness levels for such electronic signs shall not exceed 500 nits, when measured from the sign face at its maximum brightness, during night and under cloudy or other darkened conditions;
 - (vii) The maximum resolution of such signs shall be 46 millimeter (1.8 inch) pixel pitch.
 - (viii) Any electronic sign which malfunctions, fails, or ceases to operate in its usual or normal programmed manner causing therein motion, movement, flashing, or any other similar effects, shall be repaired or disconnected within 48 hours by the owner or operator of such sign; and,
 - (ix) Permit applications for such electronic signs shall be accompanied by additional documentation as set forth in Section 12.2.3.2(e) of this Ordinance.

Bardstown Sign Ordinance
effective August 22, 2008

- (c) Developments with gross floor space **more** than ten thousand (10,000) square feet and **less** than two hundred (200) feet of public road/street frontage:
- (1) Maximum number of freestanding signs. One (1) freestanding sign.
 - (2) Maximum sign area and height:
 - (aa) For freestanding signs with a maximum height of seven (7) feet, the maximum sign area shall not exceed fifty (75) square feet.
 - (bb) For freestanding signs with a maximum height of twenty (20) feet, the maximum sign area shall not exceed thirty (45) square feet.
 - (cc) When a freestanding sign is located more than sixty-five (65) feet from the driving lane of a public road/street with forty-five (45) mile per hour (MPH) or greater speed limit, the maximum sign area shall not exceed seventy (100) square feet, and the maximum sign height shall not exceed ten (10) feet.
 - (3) Minimum setbacks: The minimum setback for freestanding signs shall be ten (10) feet from rear and side property lines and off of the right-of-way of any public road/street, unless otherwise stated in this Ordinance.
 - (4) Changeable copy sign: Each freestanding sign may have attached to it a changeable copy sign, provided:
 - (aa) Such sign shall not exceed one-half (1/2) the sign area of the permitted freestanding sign on which it is attached;
 - (bb) Such sign may be electronic, such as light emitting diode (LED), provided:
 - (j) Such sign shall be limited to text only, and the text shall be static and in a stationary and fixed position;
 - (ii) Such sign shall have a black opaque background and shall be limited to monochrome text in amber, green, blue, red, or white color;
 - (iii) Such sign shall not flash, scroll, chase, rotate, blink or pulsate or have any similar effects of movement;
 - (iv) Such sign shall not include any animated images and images which move or give the appearance of movement and shall not have visual messages with apparent motion caused by, but not limited to, the illusion of moving objects, moving patterns or boards of lights, expanding, contracting, or rotating shapes, scrolling or running messages, or other similar animation effects;
 - (v) Such sign shall be programmed so that the text changes no more than every minute, and such changes of text shall be substantially instantaneous as seen by the human eye and shall not use fading, rolling, window shading, dissolving, or similar effects as part of the change;
 - (vi) Such signs shall use automated light sensing devices to reduce light levels at night and under cloudy or other darkened conditions, in accordance with the following standards:
 - (vi-1) Such electronic signs shall have installed automated light sensing devices (e.g., photocell technology) and shall, at all times, allow such monitors to automatically adjust the brightness level based on ambient light conditions, and,

- (vi-2) Maximum brightness levels for such electronic signs shall not exceed 500 nits, when measured from the sign face at its maximum brightness, during night and under cloudy or other darkened conditions;
 - (vii) The maximum resolution of such signs shall be 46 millimeter (1.8 inch) pixel pitch.
 - (viii) Any electronic sign which malfunctions, fails, or ceases to operate in its usual or normal programmed manner causing therein motion, movement, flashing, or any other similar effects, shall be repaired or disconnected within 48 hours by the owner or operator of such sign; and,
 - (ix) Permit applications for such electronic signs shall be accompanied by additional documentation as set forth in Section 12.2.3.2(e) of this Ordinance.
- (d) Developments with gross floor space **more** than ten thousand (10,000) square feet and **more** than two hundred (200) feet of public road/street frontage:
- (1) Maximum number of freestanding signs. Two (2) freestanding signs.
 - (2) Maximum sign area and height:
 - (aa) For freestanding signs with a maximum height of seven (7) feet, the maximum sign area shall not exceed fifty (75) square feet.
 - (bb) For freestanding signs with a maximum height of twenty (20) feet, the maximum sign area shall not exceed thirty (45) square feet.
 - (cc) When a freestanding sign is located more than sixty-five (65) feet from the driving lane of a public road/street with forty-five (45) mile per hour (MPH) or greater speed limit, the maximum sign area shall not exceed seventy (70) square feet, and the maximum sign height shall not exceed ten (10) feet.
 - (3) Minimum setbacks: The minimum setback for freestanding signs shall be ten (10) feet from rear and side property lines and off of the right-of-way of any public road/street, unless otherwise stated in this Ordinance.
 - (4) Minimum sign separation: The minimum separation between two (2) freestanding signs on a lot or tract shall be one hundred fifty (150) feet.
 - (6) Changeable copy sign: Each freestanding sign may have attached to it a changeable copy sign, provided:
 - (aa) Such sign shall not exceed one-half (1/2) the sign area of the permitted freestanding sign on which it is attached;
 - (bb) Such sign may be electronic, such as light emitting diode (LED), provided:
 - (k) Such sign shall be limited to text only, and the text shall be static and in a stationary and fixed position;
 - (ii) Such sign shall have a black opaque background and shall be limited to monochrome text in amber, green, blue, red, or white color;
 - (iii) Such sign shall not flash, scroll, chase, rotate, blink or pulsate or have any similar effects of movement;
 - (iv) Such sign shall not include any animated images and images which move or give the appearance of movement and shall not have visual messages with apparent motion caused by, but not

limited to, the illusion of moving objects, moving patterns or boards of lights, expanding, contracting, or rotating shapes, scrolling or running messages, or other similar animation effects;

- (v) Such sign shall be programmed so that the text changes no more than every minute, and such changes of text shall be substantially instantaneous as seen by the human eye and shall not use fading, rolling, window shading, dissolving, or similar effects as part of the change;
- (vi) Such signs shall use automated light sensing devices to reduce light levels at night and under cloudy or other darkened conditions, in accordance with the following standards:
 - (vi-1) Such electronic signs shall have installed automated light sensing devices (e.g., photocell technology) and shall, at all times, allow such monitors to automatically adjust the brightness level based on ambient light conditions, and,
 - (vi-2) Maximum brightness levels for such electronic signs shall not exceed 500 nits, when measured from the sign face at its maximum brightness, during night and under cloudy or other darkened conditions;
- (vii) The maximum resolution of such signs shall be 46 millimeter (1.8 inch) pixel pitch.
- (viii) Any electronic sign which malfunctions, fails, or ceases to operate in its usual or normal programmed manner causing therein motion, movement, flashing, or any other similar effects, shall be repaired or disconnected within 48 hours by the owner or operator of such sign; and,
- (ix) Permit applications for such electronic signs shall be accompanied by additional documentation as set forth in Section 12.2.3.2(e) of this Ordinance.

11.3.2.2.2 Building Signs.

(a) Maximum number of signs:

- (1) Individual principal use: Each individual principal use located on an individual lot is allowed maximum three (3) building signs, unless otherwise allowed herein.
- (2) Multi-tenant and multi-use building with two (2) or more principal uses without their own separate exterior building entrances and exits and sharing a common hallway: The building shall be permitted three (3) building signs, and the sign sizes shall be based on the size of elevation as set herein, unless otherwise allowed.
- (3) Multi-tenant and multi-use buildings and developments where a single building or complex of buildings contains two (2) or more individual principal uses with their own separate exterior building entrances and exits: Unless otherwise allowed in this Ordinance, the number and size of building signs for each individual principal use located within the development shall be based on the portion of the building elevation occupied by the individual principal use, as set forth below, as though they were individual and independent buildings.

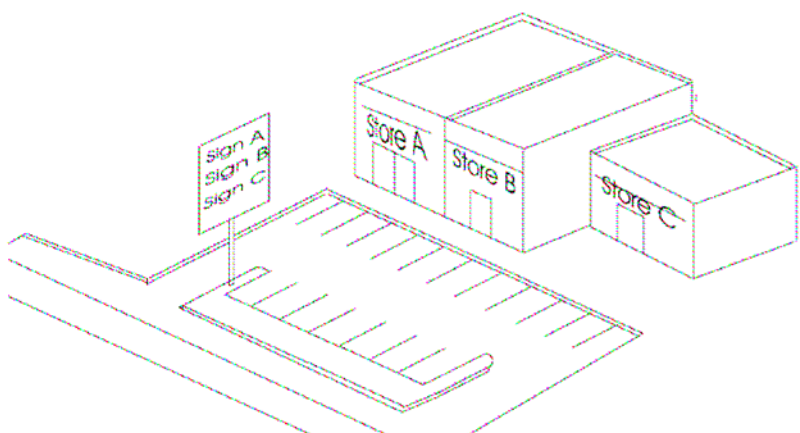

*Illustration 11-1.
Multi-use building sign types.*

(b) Total Allowable Building Sign Area Per Elevation:

- (1) If the principal use has no freestanding signs, then the total allowable sign area for building signs shall be as follows:
 - (aa) If the business has a total of three (3) building-mounted signs, each sign may be up to 7%;
 - (bb) If the business has a total of two (2) building-mounted signs, up to 9%; or,
 - (cc) If the business has only one (1) building-mounted sign, up to eleven percent (11%).
- (2) If the principal use has one (1) freestanding sign, then the total allowable sign area for building signs shall be as follows:
 - (aa) If the principal use has a total of three (3) building signs, each sign may be up to five percent (5%) of the building elevation or thirty (30) square feet, whichever is larger;
 - (bb) If the principal use has a total of two (2) building signs, each sign may be up to seven percent (7%) of the elevation; or,
 - (cc) If the business has only one (1) building sign, each sign may be up to nine percent (9%).
- (3) If the principal use has two (2) freestanding signs, then the total allowable building sign area is:
 - (aa) If the principal use has a total of two (2) building signs, each sign may be up to seven percent (7%) of the elevation; or,
 - (bb) If the business has only one (1) building sign, each sign may be up to nine percent (9%).

(c) Building-mounted signs shall not extend above the peak, or highest point of the roof.

(d) Projecting Signs.

- (1) A projecting sign shall be a substitute for, or in lieu of, one (1) permanent sign for the principal use;
- (2) The sign shall have nine (9) feet of clearance above sidewalk;
- (3) The sign shall not project more than ten (10) feet from building nor be any closer than eighteen (18) inches from curb or driving lane;
- (4) The sign shall not extend above the peak of the roof; and,

**Bardstown Sign Ordinance
effective August 22, 2008**

- (5) A two or more story building shall not have projecting signs above twenty (20) feet high.

11.3.2.2.3 Off-Premise Signs for lots which are permitted a freestanding sign, provided:

- (a) The subject lot does not front a major artery or collector street, as identified in the Comprehensive Plan;
- (b) The subject lot is not located within the Central Business District, as defined by the Zoning Ordinance;
- (c) The subject lot is not in Light Industrial Park, as defined by the Zoning Ordinance;
- (d) The subject lot is not located in a shopping center, as defined by the Zoning Ordinance;
- (e) The on-site conforming sign would not be visible from a major artery or collector street;
- (f) The permitted off-site sign shall not exceed the size, height, and setbacks requirements of the free-standing sign of the lot on which it is located;
- (g) The off-site sign may not be located within fifty (50) feet of any other freestanding sign;
- (h) The off-site sign shall be in lieu of a free-standing sign for the lot on which it is located, and,
- (i) Written evidence of property owner consent must be submitted with the permit application.

11.3.2.2.4 Visual Elements, provided:

Illustration 11-2: Visual Element

- (a) One (1) permanent and ground-mounted visual element per individual principal use shall be permitted as a substitute for, or in lieu of, one (1) permanent sign allowed for the use;
- (b) The maximum size of the visual element shall be computed by means of the smallest cube that will encompass the extreme limits of the visual element and with maximum cube dimensions of seven (7) feet in height, four (4) feet in depth, and four (4) in width;
- (c) Parts of the visual element may not extend more than 20 percent beyond the limits of the allowable area set forth in Section (b) above;
- (e) Visual elements shall have no parts that move or give the appearance of movement and shall have no apparent motion caused by, but not limited to, the illusion of moving objects, moving patterns or boards of lights, expanding, contracting, or rotating shapes, scrolling, or running messages or other similar animation effects;
- (f) Visual elements must be securely installed or displayed and shall be constructed or designed in a manner which shall cause the sign to be confused or interfere with a traffic sign or other traffic control device; and,
- (g) Commercial messages, logos, or symbols shall be limited to two (2) sides of the visual elements and shall not exceed ten (10) square feet.



11.3.2.2.5 Landmark signs, provided:

- (a) Such signs shall be exempt from size, height, and setback regulations, but shall comply with all other regulations set forth in this Ordinance, and,
- (b) Such signs shall not encroach into a public right-of-way, unless otherwise allowed by an approved entrance permit by the appropriate governing authority.

**Bardstown Sign Ordinance
effective August 22, 2008**

11.3.2.2.6 Accessory Building Signs, provided:

- (a) One (1) building sign on an accessory building shall be permitted in addition to the building signs allowed for the individual principal use;
- (b) The maximum sign area shall not to exceed one (1) square foot per linear foot of the building length of and on the elevation on which the sign is located and facing the public street or private access way if the lot has no public street frontage; and,
- (c) Additional accessory building signs may be allowed but shall be a substitute for, or in lieu of, the permitted building signs for the individual principal use and shall comply with the maximum number and size of building signs allowed for the individual principal use.

11.3.2.2.7 Freestanding Canopy Signs, provided:

- (a) One (1) sign on each canopy elevation (fascia) shall be permitted;
- (b) Such signs shall not exceed eight (8) square feet; and,
- (c) Such signs shall be permitted in addition to the building signs allowed for the individual principal use.

11.3.2.2.8 Light Industrial Commercial Park (LIP) Identification Signs, provided:

- (a) One (1) sign per public street entrance shall be permitted;
- (b) Such signs shall not exceed forty (40) square feet in area;
- (c) A listing of individual businesses and industries shall be allowed as part of the identification sign; and,
- (d) Written evidence of property owner consent must be submitted with the permit application.

Section 12: Permit Process & Procedures

12.1 Permit Required. Except as otherwise provided in this Ordinance, it shall be unlawful for any person to erect, construct, install, mount, place, apply, paint, attach, affix, expand, enlarge, move, modify, or replace any sign or cause the same to be done, without first obtaining a sign permit.

12.2 Application and Permit Issuance.

12.2.1 If a sign requiring a permit under the provision of this Ordinance is to be erected, constructed, installed, mounted, placed, applied, painted, attached, affixed, expanded, enlarged, moved, modified, or replaced on a property, the property owner shall secure a sign permit prior to the construction, placement, erection, or modification of the sign.

12.2.2 No sign permit of any kind shall be issued for an existing or proposed sign unless the sign is consistent with the requirements of this Ordinance (including those protecting existing signs) in every respect and with the Sign Plan in effect for that property.

12.2.3 The following procedures shall govern the application for and issuance of all sign permits under this Ordinance and the submission and review of Sign Plans:

12.2.3.1 Sign Plan Required. No permit shall be issued for an individual sign requiring a permit until a Sign Plan for the property on which the sign will be installed has been submitted to and approved by the Administrator as conforming with this section.

12.2.3.2 Sign Plan Contents. For any property on which the owner proposes to erect one (1) or more signs requiring a permit, the owner shall submit to the Administrator a Sign Plan containing the following:

- (a) An accurate plot plan of the property, at such a scale as the Administrator may reasonably require;
- (b) Location of buildings, structures, parking lots, driveways, and landscaped areas of the property;

**Bardstown Sign Ordinance
effective August 22, 2008**

- (c) Computations of the maximum total sign area, the maximum area for individual signs, the height of signs and the number of building and freestanding signs allowed on the property included in the plan under this Ordinance;
- (d) An accurate indication on the plot plan of the proposed location of each present and future sign of any type whether requiring a permit or not; and,
- (e) For electronic changeable copy signs:
 - (1) Specifications from the manufacturer providing the maximum nit (or equivalent) rating of the sign;
 - (2) Documentation from the manufacturer indicating that the sign is equipped with the required automated light sensing device; and,
 - (3) A notarized letter signed by the property owner acknowledging the owner's agreement to abide by this Ordinance requiring automatic level controls to reduce light levels at night and under cloudy or other darkened conditions.

12.3 Fees.

12.3.1 Permit Fees. No sign permit shall be issued until all applicable fees have been paid. The fees for sign permits, beginning with the adoption of this Ordinance, shall be \$28 per sign. The sign permit fee shall be adjusted annually based on the consumer price index (CPI), rounded to the nearest percentage, as established by the Kentucky Governor's Office for Local Development.

12.3.2 Late Fees. In addition to the sign permit fees, the Sign Administrator shall also assess a \$50 late fee to any applicant who erects, places, establishes, paints, installs, creates, or in any other way initiates a sign prior to receiving the property permit or approval from the Sign Administrator. This fee is in addition to, and not in lieu of, any penalties for violations of the regulations. Payment of this late fee will in no way exonerate or excuse the applicant from applying in an appropriate manner and complying with the normal requirements and standard permit fees for the permission or applicable permit which is needed.

12.4 Review. Within five (5) days of submission of a sign permit application, the Sign Administrator shall review the application for completeness. If the application is complete, the Sign Administrator shall process the application. If the application is incomplete, the Sign Administrator shall notify the Applicant of the deficiencies and reference the appropriate sections of this Ordinance. Upon correcting the deficiencies, the Sign Administrator will process the application.

12.5 Issuance of Permits. Within seven (7) days of the submission of a complete application for a sign permit, the Administrator shall either:

- 12.5.1 Issue the sign permit, if the sign that is the subject of the application conforms in every respect with the requirements of this Ordinance and the applicable Sign Plan; or,
- 12.5.2 Deny the sign permit, if the sign that is the subject of the application fails in any way to conform with the requirements of this Ordinance and of the applicable Sign Plan. In case of a rejection, the Sign Administrator shall specify in the rejection the Section or Sections of the Ordinance or applicable plan with which the sign is inconsistent.

Section 13: Non-Conforming Signs.

13.1 For the purpose of this Section, a non-conforming sign shall be defined as a sign existing at the effective date of this Ordinance which could not be built under the terms of this Ordinance or under the terms of other applicable local ordinances. The following requirements apply to the continued use of and/or replacement of non-conforming signs:

13.1.1 Continued Use: A non-conforming sign may continue to be used by the establishment occupying the structure on the site for which the sign was originally erected, as long as no major structural support element (frame, pole, bracing, etc.) is replaced. If a major structural support element is to be replaced, due to voluntary action by the owner, or due to

**Bardstown Sign Ordinance
effective August 22, 2008**

some act of God or unforeseen circumstance, then the “new” sign to be erected must be in compliance with this Ordinance.

- 13.1.2 Replacement: The sign face of a non-conforming sign may be replaced as long as no major structural element of the sign is replaced. As stated above, if a major structural element is to be replaced, then the new sign to be erected must be in compliance with this Ordinance.
- 13.1.3 Where a change in use, occupancy, or ownership occurs which necessitates the altering of a sign in any manner, then the altered or changed sign shall be brought into conformance with the requirements of this Ordinance.
- 13.1.4 Existence of a non-conforming building sign on the premises will prohibit issuance of further building sign permits while the non-conforming sign exists.
- 13.1.5 Existence of a non-conforming freestanding sign on the premises will prohibit the issuance of further freestanding sign permits while the non-conforming sign exists.

Section 14: Violations, Enforcement & Penalties.

14.1 Signs Forfeited. Any sign installed or placed on or over public property or right-of-way after adoption of this Ordinance, except in conformance with these requirements, shall be forfeited to the public and subject to confiscation. In addition to other remedies hereunder, the City shall have the right to recover from the owner or person placing such a sign the full cost of removal and disposal of the sign.

14.2 Violations.

14.2.1 Any of the following shall be a violation of this Ordinance and shall be subject to the enforcement remedies and penalties provided by this Ordinance and by state law:

- 14.2.1.1 To install, create, erect, or maintain any sign in a way that is inconsistent with any plan or permit governing such sign or the lot on which the sign is located.
- 14.2.1.2 To install, create, erect or maintain any sign requiring a permit without such a permit.
- 14.2.1.3 To fail to remove any sign that is installed, created, erected, or maintained in violation of this Ordinance, or for which the sign permit has lapsed.

14.2.2 Each day of a continued violation shall be considered a separate violation when applying the penalty portions of this Ordinance.

14.3 Enforcement.

14.3.1 The Sign Administrator shall have the authority to issue citations for violations of this Ordinance but shall not have powers of peace officers to make arrests or carry deadly weapons. A person receiving a citation shall appear within a designated time pursuant to the citation.

14.3.2 Any violation or attempted violation of this Ordinance or of any condition or requirement adopted pursuant hereto may be restrained, corrected, or abated, as the case may be, by injunction or other appropriate proceedings pursuant to state law. The remedies of the City shall include, but are not limited to the following:

- 14.3.2.1 Issuing a stop-work order for any and all work on any signs on the same lot;
- 14.3.2.2 Seeking an injunction or other order of restraint or abatement that requires the removal of the sign(s) or the correction of the non-conformity; and,
- 14.3.2.3 In the case of a sign that poses an immediate danger to the public health or safety, take such measures as are available to the City under the applicable building codes or other ordinances.

14.3.2 All the remedies provided herein shall be cumulative. To the extent that state law may limit the availability of a particular remedy set forth herein for a certain violation or a part hereof, the remedy shall remain available for other violations or other parts of the same violation.

**Bardstown Sign Ordinance
effective August 22, 2008**

14.4 Penalties.

- 14.4.1 Violation of the provisions of the Ordinance or failure to comply with any of its requirements shall constitute a misdemeanor. Any person who violates this Ordinance or fails to comply with any of its requirements shall upon conviction thereof be fined not less than fifty dollars (\$50.00) nor more than five hundred dollars (\$500.00). Each day such violation continues shall be considered a separate offense.
- 14.4.2 The owner and also, if applicable, the tenant of any building, structure, premises or part thereof, who commits, participates in, or maintains the violation may be found guilty of a separate offense and suffer the penalties herein provided.
- 14.4.3 Nothing herein contained shall prevent the City from taking such other lawful action as is necessary to prevent or remedy any violation.